

Plasma Effects on Bacterial Spores in a Wet Environment

Spencer P. Kuo^{1†}, Olga Tarasenko^{2†}, Said Nourkbash³, Assya Bakhtina⁴,
and Kalle Levon⁴

¹Department of Electrical and Computer Engineering, Polytechnic University, Brooklyn, NY, 11201

²Department of Biology, University of Arkansas at Little Rock, Little Rock, AR, 72204

³Department of Mechanical Engineering, Polytechnic University, Brooklyn, NY, 11201

⁴Department of Chemical and Biological Sciences and Engineering, Polytechnic University, Brooklyn, NY, 11201

E-mail: skuo@duke.poly.edu

[†]These authors are contributed equally to this work.

Abstract. An arc-seed microwave plasma torch, which can run stably at low airflow rate (e.g., 0.393 l/s) and produces an abundance of reactive atomic oxygen in its plasma effluent, is applied for studying the effects of atomic oxygen on bacterial spores in solution. *Bacillus cereus* was chosen as the biological agent. The experimental results show that the plasma effluent can penetrate into water to kill *B. cereus* spores. The kill time (i.e., 10-fold reduction time) is about 10 seconds at an exposure distance of 3 cm, 24 seconds at 4 cm, and 31 seconds at 5 cm. Morphological studies are performed via scanning electron and atomic force microscopes, which take two and three-dimensional images of spores to record the changes in their morphological structures and shapes caused by the plasma effluent. The loss of appendages and exosporium in the structure as well as flattened cell shapes are observed.

Contents

1. Introduction	2
2. Experiments	3
2.1. Experimental setup	3
2.2. Sample preparations prior to and after exposure	4
2.3. Experiments and results	5
3. Morphological Studies	6
3.1. Scanning electron microscopy (SEM)	6
3.2. Atomic Force Microscopy (AFM)	8
4. A Plausible Mechanism	10
Acknowledgements	13
References	13

1. Introduction

Variety *Bacillus* produces a dormant cell type called a spore in response to nutrient-poor conditions [1,2]. The spore consists of the following main parts: appendages, exosporium, outer coat, inner coat, cortex, and core [3-9]. Each vegetative cell forms one spore and undergoes lysis after the sporulation process is complete. The spore grows exclusively in the mammalian host where spores germinate within the presence of rich conditions such as amino acids, sugars, adequate pH, water, and a favorable temperature [2,10].

The longevity of spores in the environment is an important factor in the epidemiology of anthrax and explains the predominant occurrence of the disease in herbivores. *B. anthracis*, the etiologic agent of anthrax, is a large, gram-positive, rod-shaped, non-motile, facultative anaerobic, spore-forming bacterium that causes disease in humans and herbivore animals [11,12]. *Bacillus cereus*, *Bacillus anthracis*, *Bacillus thuringiensis* species, along with *Bacillus mycooides*, are known to belong to the *B. cereus* group [13,14]. *B. anthracis* exhibits genetic similarities with *B. cereus* [13,14]. Indeed many consider them to be the same species [15,16].

Spore is highly resistant to a variety of treatments including ultraviolet and ionizing radiation, pressure and heat [3,17-19]. Its coats shield the core from UV radiation; thus UV

treatment has little effect on the spore and leaves the spore's immunology almost unchanged [20]. The membranes enable the spore to endure high pressure (100 - 200 Mpa). Low water content in the core makes the spore heat resistant. Moreover, spores are most refractory to inactivation by the boiling water method [21-23], which takes about 12 minutes to destroy *B. anthracis* spores [22]. Stein and Rogers [23] reported that vigorous boiling could reduce the time to within 3 to 5 minutes to destroy spores from 43 strains of *B. anthracis*. Boiling water in a covered vessel killed spores of the *Bacillus*, reducing the spore population by more than four orders of magnitude [24] in 3 to 5 minutes. Holding water at a rolling boil could further reduce the time to about 1 minute to inactivate waterborne pathogens, including encysted protozoa [25-27]; however, it would not inactivate the spores [24] even by increasing the boiling time to 3 minutes as an open container was used.

In the present work, experiments were conducted to study the effect of plasma on bacterial spores in water in addition to the ultimate effect of killing them [28-30]. The reactive radicals that could interact with the spores were generated directly in the plasma effluent or indirectly in water by an arc-seed microwave plasma torch (MPT) [31]. *B. cereus* bacterial spores were chosen as a simulant for the *B. anthracis*. The changes on the morphological characteristics of the spore during the exposure to the plasma effluent were recorded by scanning electron microscope (SEM) and by atomic force microscope (AFM).

2. Experiments

2.1. Experimental setup

The MPT was secured on a fixed vertical lift platform with its 1.25-cm-diameter circular nozzle exit facing downward. A second vertical lift platform directly below the nozzle exit was used to position the surface level of the plate below the MPT nozzle. The plasma effluent was directed downward, toward four samples simultaneously, in each run with this arrangement. A schematic of the experimental setup is presented in Fig. 1. As shown, The components of the MPT device include 1) A magnetron (2.45 GHz, 700 W) as the microwave source, 2) A tapered microwave cavity, and 3) An arc-torch module; the power supply to run the torch module and magnetron simultaneously is not shown. The torch was run at an airflow rate of 0.393 l/s, which was

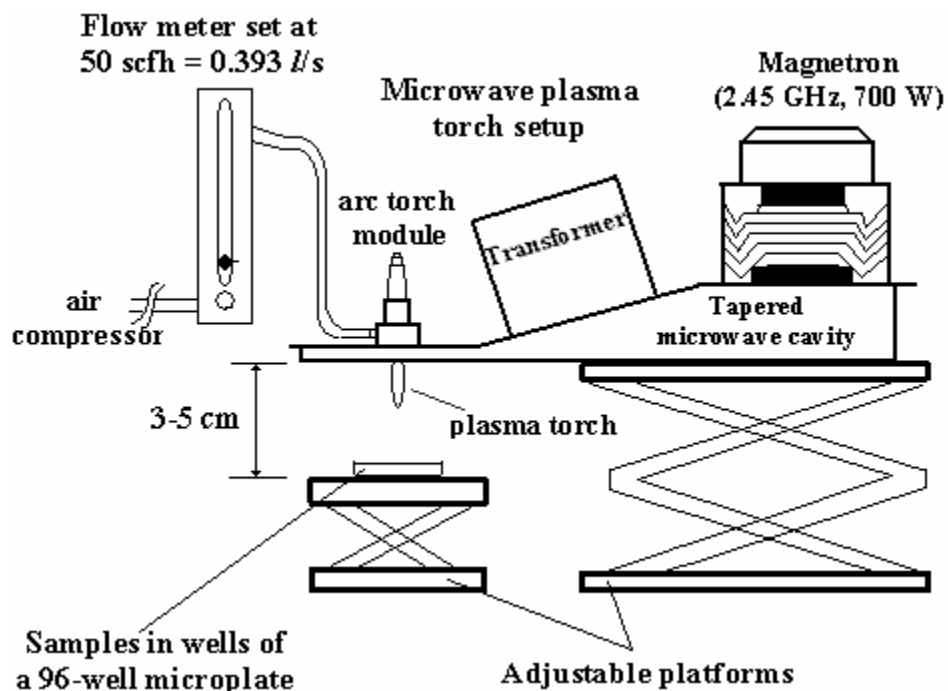

Figure 1. Schematic of the experimental setup.

identified via emission spectroscopy to be the optimal condition to produce radicals (mainly atomic oxygen) in the plasma effluent of the torch. Three vertical distances of 3, 4, and 5 cm, and exposure times of 2 to 16 seconds were chosen for the samples. It has been examined before the experiments that at these distances and exposure times, the torch run at this airflow rate of 0.393 l/s will not cause noticeable desiccation of water sample in a well, a same arrangement as the experiments.

2.2. Sample preparations prior to and after exposure

Drops of bacterial-spore solution (sterile bacterial spore suspension of *B. cereus* ATCC 11778 (3.5×10^6 CFU/0.1ml, where CFU stands for colony forming units)), 30 μ l each, were inoculated onto the wells of 96-well microplates that contain about 10^6 spores per well. Subsequently, each plate was placed on the stage below the plasma torch nozzle. Two sets of experiments were

independently performed twice. Each measurement was repeated 3 times. The processing of the samples after plasma treatment involved the following procedures. Volumes of solutions of untreated and post-exposed spore samples were checked to make sure that the 30 μ l dripped initially into each well of the plate was not reduced by more than 5% (controlled by the exposure distance and time). The post-exposure sample-handling was performed as follows: spores and debris in each well of the plate were diluted using W3500 tissue culture water (60ml/well) and mixed by means of extensive continuous shaking for 1 hr at 25⁰ C. The mixtures of post-exposed samples were serially diluted from 10⁻¹ to 10⁻⁵. Those mixtures were plated onto petri dishes with Tryptic Soy (TS) liquid media and incubated at 37⁰C for 16 hours. After the incubation, the resulting colony forming units (CFU) were counted through their images in the taken pictures. Only the mixtures with 10⁻² dilution were chosen for analysis. The results of the counted CFU then compared with the control CFU (about 10⁴ per diluted sample before the treatment) to determine the decontamination efficacy (i.e., the survival curves or called “kill curves” in some literatures).

2.3. Experiments and results

At 3 cm distance, the exposure times were 2, 4, 6, and 8 seconds. At 4 and 5 cm distances, longer exposure times of 4, 8, 12, and 16 seconds were used. The lines fitting the data points presented in Fig. 2 represent the kill curves for *B. cereus* spores in solution exposed to the plasma torch effluent at the three exposure distances: three exposure distances of 3 cm (●), 4 cm (○), and 5 cm (+). The x-axis is the exposure time in seconds; the y-axis displays the log₁₀ of the ratio of the remaining number of viable spores (N) to the CFU control number (N₀) and covers the range down to -1 log. The time required to reduce the viable *B. cereus* spore population by a factor of 10 by the MPT in this graph for 3, 4 and 5 cm distances are calculated to be 10, 24, and 31 seconds, respectively.

Since 3 cm distance was most effective in the experiments (Fig. 2), the treated samples (of 10⁻² dilution) at 3 cm distance were used in the SEM and AFM studies discussed in the following sections. SEM produces a two-dimensional (2-D) image to reveal the actual shape and the morphological structure of a bacterial spore, while AFM examines spore’s cell properties by taking a three-dimensional (3-D) image.

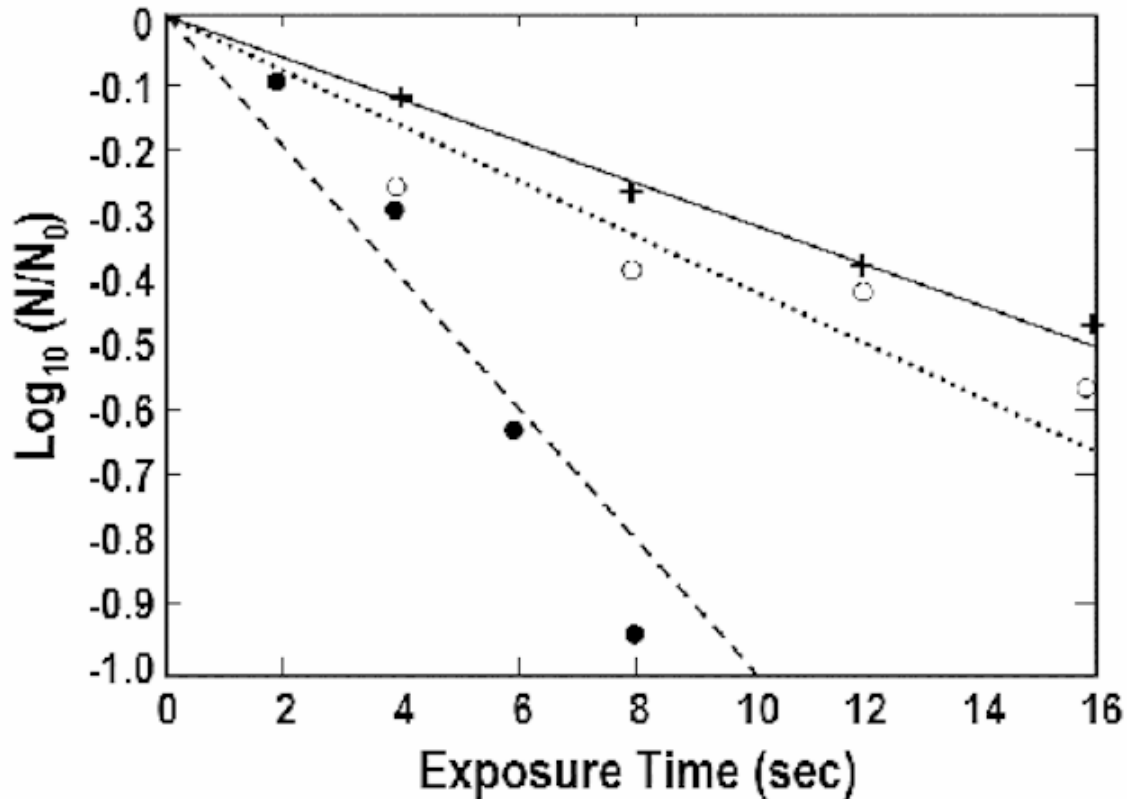

Figure 2. BC kill curves; data points are obtained by placing wet samples (*B. cereus* spores in water) at three exposure distances of 3 cm (●), 4 cm (○), and 5 cm (+) from the nozzle of a microwave plasma torch.

3. Morphological Studies

3.1. Scanning electron microscopy (SEM)

Solutions of untreated (10^4 CFU) and post-exposed spore samples for SEM observations were deposited on mica disks and desiccated for 7 days. Samples were then coated with a 10 nm thin film of evaporated gold [32] for 60 sec and then observed with a SEM at an accelerating voltage of 15-20 kV. The images of untreated (Fig. 3a) and exposed but still viable *B. cereus* spores (Figs. 3b-d) were taken at low (left column) and high (right column) magnification for examination. Comparing images of individual spores (right column) exposed to the plasma effluent for different time periods with that of the control reveals the changes of the actual shapes and morphological structures of bacterial spores during the exposure. The images of grouping

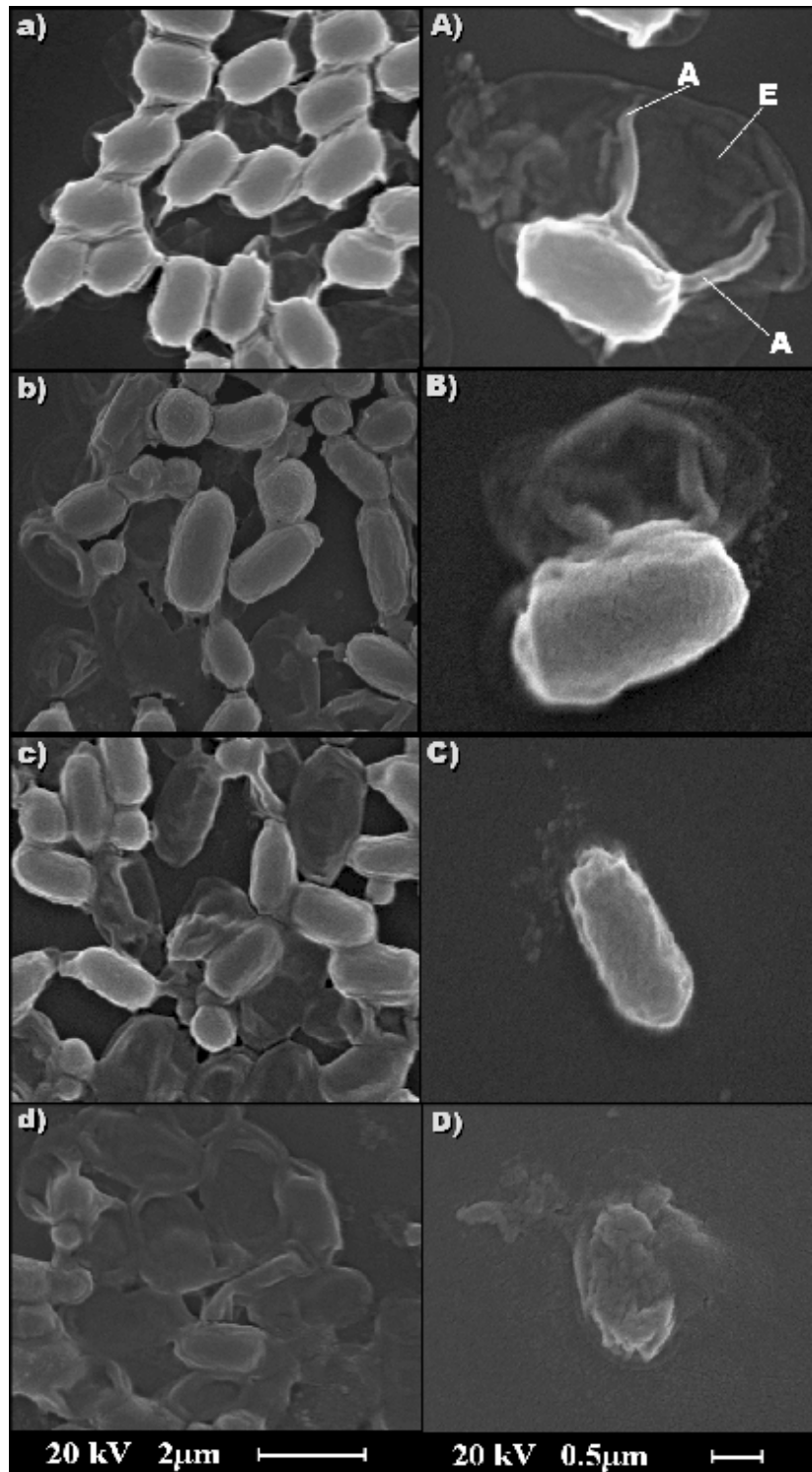

Figure 3. SEM images of *B. cereus* spores; (a) untreated and (b)-(d), exposed to the plasma torch at 3 cm distance for (b) 2 sec., (c) 4 sec., and (d) 8 sec at low (left column) and high (right column) magnification. In (a), **A** stands for appendages, **E** for exosporium.

spores in the left column show the integrity of spores. In the case of the 2 sec exposure shown in Fig. 3b, the spores have kept their integrity; exosporium and appendages of a spore are still visible, but its size seems to increase considerably from that of the untreated spore (Fig. 3a). Spores after 4 sec exposure show changes in morphology. As seen in Fig. 3c, the spore has lost its appendages, its exosporium has shrunk and its size has decreased drastically. However, the actual change of spore's size has to be further checked by the corresponding 3-D images presented in the following section. Exposure for 8 sec has drastically changed spore's morphology. Fig. 3d indicates that spores have lost integrity; neither appendages nor exosporium of a spore can be seen.

3.2. Atomic Force Microscopy (AFM)

Solutions of untreated sample (10^4 CFU) and those after exposure were immobilized on mica discs using sterile syringes, and then dried in air at 20° C. Prepared samples were later mounted on an AFM sample holder for imaging. All AFM observations were carried out at 20° C, using a Nano Scope[®] IIIa controller as well as a MultiMode[™] microscope operating in tapping mode (amplitude) together with an E-scanner. A 125- μ m silicon Nanoprobe was also employed. The calculated spring constant was 0.3 N/m. The resonance frequency remained in the range of 240-280 kHz, and the scan rate was 1 μ m/s. Flattening and high-pass filtering of the image data were performed to remove the substrate slope from images as well as high-frequency noise strikes, which are, otherwise, more pronounced in the high-resolution tapping mode imaging. Images of untreated *B. cereus* spores and three treated spores corresponding to the three exposure times, 2, 4, and 8 sec, are presented in Figs. 4a-d. As seen in Fig. 4a, the cell of the untreated one has a bubbling shape in the middle region. After the exposure, the cell is squashed in the middle region and becomes elongated and wider as seen in Figs. 4b-d. The middle part of the cell is flattened and the flattened region expands toward the two ends as the exposure time increases. It is noted that the 3-D images in column C of Fig. 4 have different spatial scales. The axes on the horizontal plane in (b) and (c) of column C extend to 5 μ m, rather than that of 3 μ m for the other two figures. The vertical axis extends to 2 μ m in (a), and to 1 μ m in the others.

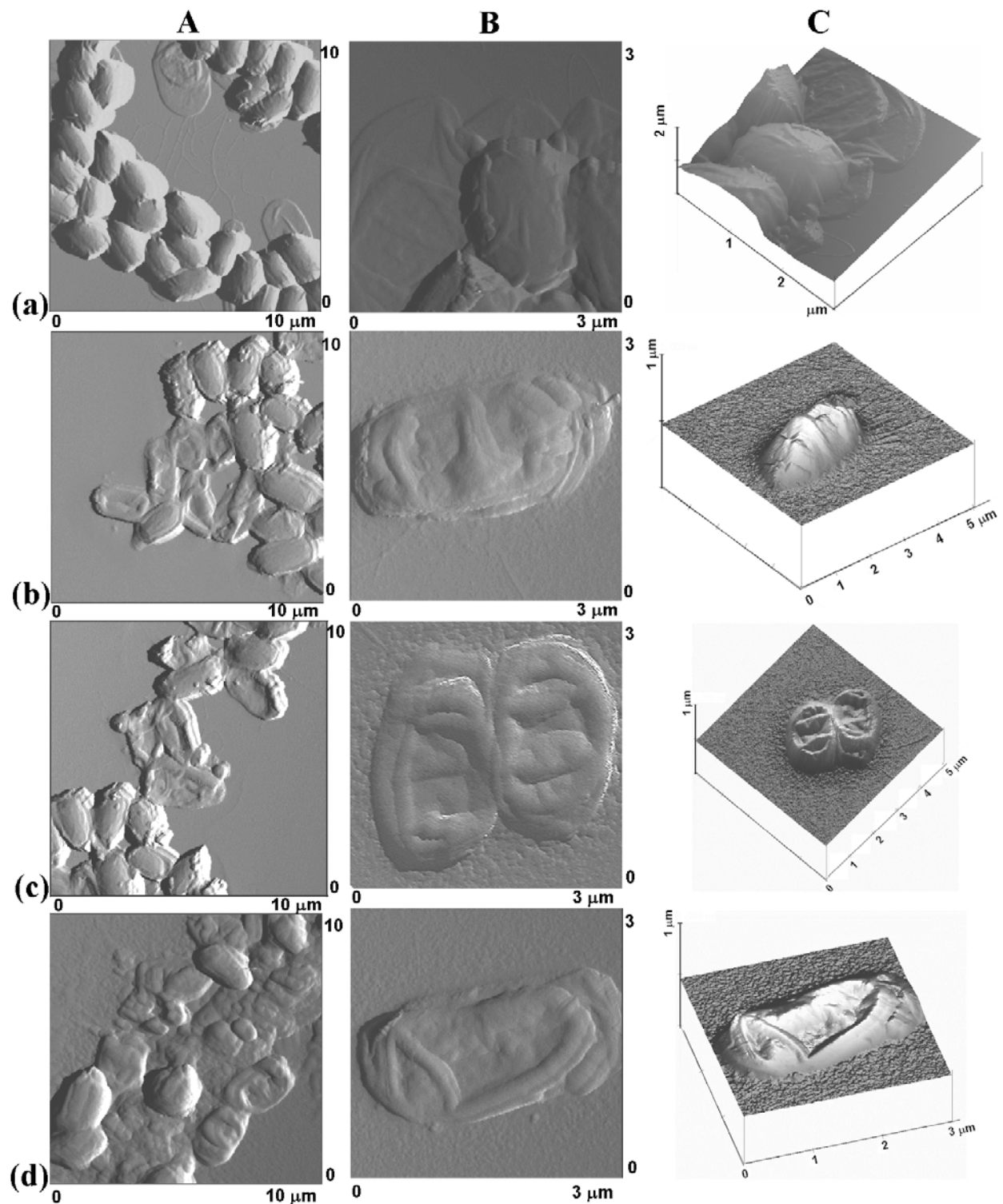

Figure 4. AFM images of *B. cereus* spores; (a) untreated and (b)-(d), exposed to the plasma torch at 3 cm distance for (b) 2 sec., (c) 4 sec., and (d) 8 sec.; from left to right are amplitude images at low (column A) and high (column B) resolution, and 3D images (column C).

4. A Plausible Mechanism

A thermo probe was used to check the water temperature increase by the torch. This was performed with the water drop in a petri dish, rather than in a 96-well microplate (it is not possible to put the probe in the well properly). Therefore, the volume of the water drop in the petri dish was larger than that in the well of the microplate. The temperature increase was negligibly small. We have also exposed the thermo probe directly to the torch (at a distance ≥ 3 cm) without covering by a water drop; the temperature increase never exceeded 45°C . Moreover, we have placed a piece of paper at the sample location (~ 3 cm) and found that the plasma torch could not even make a noticeable burn mark on the paper; however, it was also understood that the ignition point of paper is 233°C . On the other hand, the vaporization of the sample solution was less than 5% of the volume after the exposure; it suggested that the gas temperature of the torch at the sample location could not be high. Therefore, thermal process as the decontamination mechanism is ruled out.

The diameter of the circular nozzle exit of the torch on the cavity surface is about 1.25 cm, which is much smaller than the wavelength of about 12.3 cm. Hence, it is not likely the evanescent fields leaking out of the cavity could maintain significant amplitudes, even at the closest sample location (3 cm away from the exit hole), to directly interact with spores. For the safety reason, a microwave leakage detector (MD-2000) was used in experiments to monitor the level of the microwave flux. It was found that the power flux at 1 m distance away was less than 1 mW/cm^2 , which was within the safety threshold level of 5 mW/cm^2 . Moreover, 2.45 GHz is a resonant frequency of water. Thus, microwave would be absorbed by water before causing effect on the spores. Since the water temperature was not raised noticeably, it was another indication that the microwave leakage could not be high. Thus, we also rule out the possibility that the leaked microwave radiation or the evanescent fields could be responsible for the observed changes on the morphological characteristics of the spore as well as killing of spores.

Chemically reactive oxygen species (ROS), such as atomic oxygen, molecular singlet oxygen and ozone [9-10,17-19] are known to be effective in mortality and destruction of spores, and atomic oxygen is probably the most effective one among them in decontamination. However, the required energy to dissociate an oxygen molecule into two oxygen atoms is quite high; the reaction

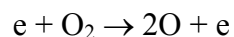

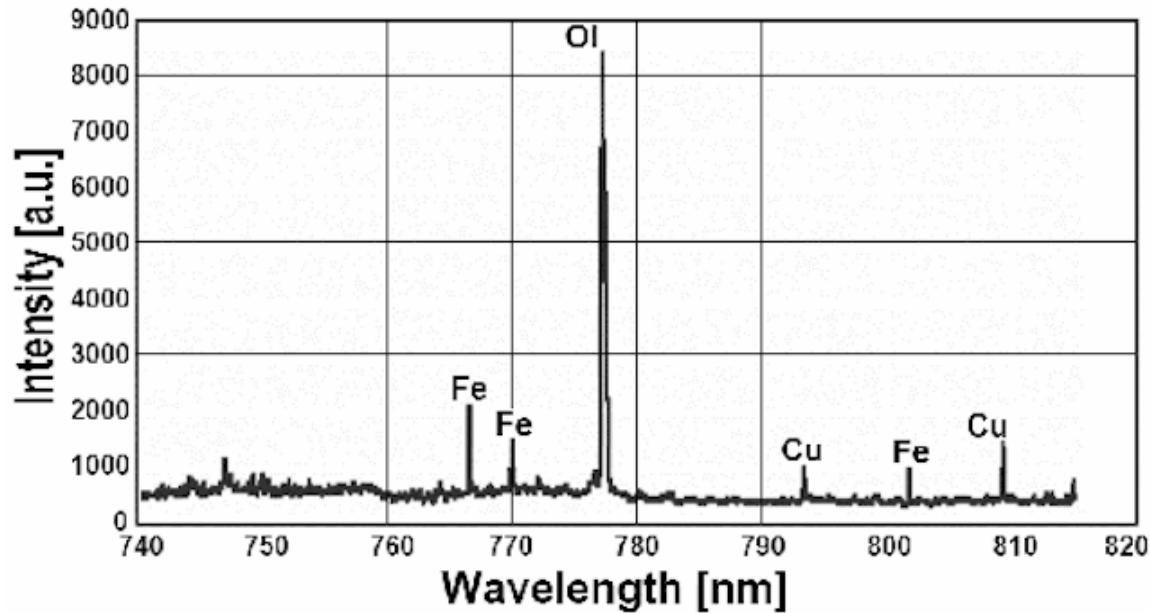

Figure 5. Emission spectrum of the microwave plasma torch; the airflow rate is 0.393 l/s and the line of sight of measurement is at 2 cm above the surface of the waveguide cavity, placed with the circular nozzle exit of the torch facing upward.

has the reaction rate coefficient [33] $k_1 = 4.2E-9\exp(-5.6/T_e)$; i.e., it takes about 5 eV to dissociate O_2 into atomic oxygen. On the other hand, air plasma can effectively absorb microwave waves to reach a highly energized state, which can be the catalyst to produce atomic oxygen in the airflow. This is indeed the case that the present torch produces an abundance of reactive atomic oxygen. Emission spectroscopy of the torch has been examined. In this study, the MPT device was placed with the circular nozzle exit of the torch facing upward (i.e., the plasma torch was generated in upward direction). Emissions were detected from a line of sight at 2 cm above the surface of the waveguide cavity. It was found that there were two dominant groups of lines in the emission spectra. One was from metallic contaminants, predominantly Fe and Cu, the material of one of the electrodes (frame of the arc torch module) and the copper cavity, present in the form of particulates in the solid phase. The other one, in the spectral region between 777.1 and 777.6 nm as shown in Fig. 5, was the atomic oxygen (O I) lines. Molecular emission spectrum of Nitrogen and Oxygen was practically nonexistent, comparing with the spectral

intensity of the OI lines and metallic lines. The emission spectrum in the UV range was also checked. UV radiation has been detected, but its intensity was not strong, comparing with that of the metallic lines. The OH line at 305 nm was buried in the metallic lines.

The intense O I (777.194 nm) spectral line, shown in Fig. 5, indicates relatively high atomic oxygen content in the torch effluent. Moreover, the large kill rates on dry samples by the same torch [30] suggest that the torch produces an abundant of reactive atomic oxygen. It is noticed that atomic oxygen can react with water to produce Hydrogen Peroxide (H_2O_2); however, H_2O_2 is not effective in killing spores. Therefore, the likely scenario is that the spores tend to float on the surface of the solution, such that the atomic oxygen produced by the MPT does not have to diffuse deeply into water to carry out decontamination. Ozone formed through the reaction of O and O_2 can also become culprit. It is also noticed that the torch contains metallic particulates. Thus, an another possibility was OH radicals formed in water through collision of metallic particulates with water molecules.

Oxidization of *B. cereus* bacterial spores by reactive radicals generated in the plasma effluent (such as O and O_3) or in water (such as OH) is then suggested to be the mechanism of killing spores in the solution. The atomic oxygen reacts with nucleic acids, lipids, proteins and sugars. The oxidation of lipids, reducing sugars and amino acids leads to the formation of carbonyls and carbonyl adducts such as 4-hydroxy-2-nonenal (HNE). The reaction with proteins also causes deamidation, racemization and isomerization of protein residues. These chemical modifications result in protein cleavage, aggregation and loss of catalytic and structural function by distorting secondary and tertiary protein structures. These irreversibly modified proteins by oxidation cannot be repaired. This occurrence is known as protein degradation [34-36]. Consequently, the morphology and physical shape of a spore are changed. The 2-D and 3-D shapes of the *B. cereus* bacterial spore before exposure (Fig. 3a and Fig. 4a) and after exposure to the plasma effluent (Figs. 3b-d and Figs. 4b-d) are recorded by SEM and AFM, respectively, for comparison. It appears that the shape of the exposed spore in Fig. 3c becomes longer and narrower than that of the untreated spore shown in Fig. 3a; moreover, destruction of spore's morphology is demonstrated in Fig. 3d. The cells of the exposed spores shown in Figs. 4c and d are squashed and flattened. Such changes on the spore's morphological structures and shape add support to the suggestion that it is the oxidation agent (atomic oxygen) in the plasma effluent cause destruction of the spores.

The kill time (i.e., 10-fold reduction time) is about 10 seconds at an exposure distance of 3 cm, 24 seconds at 4 cm, and 31 seconds at 5 cm. These times are much longer than the corresponding ones for the dry samples [30], which are directly in contact with the plasma effluent. This is understandable because the atomic oxygen in the plasma effluent has to pass through a thin water barrier before reacting with the spores.

Acknowledgements

We would like to acknowledge Professor Heng-Chun Li, Mount Sinai School of Medicine, NY, for valuable discussions. We would also like to thank reviewers for the effort to improve the presentation of this paper.

This research was supported in part by the Air Force Office of Scientific Research (AFOSR) Grant AFOSR-FA9550-04-1-0352, and in part by the Defense Advanced Research Projects Agency (DARPA) Grant 0660076225.

References

- [1] Turnbull P C B 1990 In: Principles of Bacteriology *Virology and Immunity*, 8th Edition, Arnold, London. 365
- [2] Hunter L, Corbett W and Grindem C 1989 Anthrax *J. Am. Vet. Med. Assoc.* **8** 1028-1031
- [3] Gerhardt P and Ribi E 1964 Ultrastructure of the exosporium enveloping spores of *Bacillus cereus* *J. Bacteriol.* **88** 1774-1789
- [4] Hashizuka Y and Kozuka ξ 1984 A new test of differentiation of *Bacillus cereus* and *Bacillus anthrax* based on the existence of spores appendages *Microbiol. Immunol.* **25** 1201-1207
- [5] Kozuka S and Tochikubo K 1985 Properties and origin of filamentous appendages on spores of *Bacillus cereus* *Microbiol. Immunol.* **29** 21-37
- [6] Driks A 1999 *Bacillus subtilis* spore coat *Microbiol. Molecul. Biol. Rev.* **63** 1-20
- [7] Holt S C and Leadbetter E R 1969 Comparative ultrastructure of selected aerobic spore-forming bacteria: a freeze-etching study *Bacteriol. Rev.* **33** 346-378
- [8] Hultgren S J, Abraham S, Caparon M, Falk P, St Geme J W D and Normark ξ 1993 Pilus and nonpilus bacterial adhesins: assembly and function in cell recognition *Cell* **73** 887-901
- [9] Sousa J C, Silva M T and Balassa G 1976 An exosporium-like outer layer in *Bacillus subtilis* spores

Nature **263** 53-54

- [10] Turnbull P C B, Carman J A, Lindeque P M, Joubert F, Hubschle O J B and Snoeyenbos G H 1989 Further progress in understanding anthrax in the Etosha National Park *Madoqua* **16**(2) 93-104
- [11] Baillie L and Read T D 2001 *Bacillus anthracis*, a bug with attitude! *Curr. Opin. Microbiol.* **4** 78-81
- [12] Little S F and Ivins B E 1999 Molecular pathogenesis of *Bacillus anthracis* infection, *Microbes Infect.* **2** 131-139
- [13] Read T D *et al* 2003 The genome sequence of *Bacillus anthracis* Ames and comparison to closely related bacteria *Nature* **423** 81-86
- [14] Radnedge L, Agron P G, Hill K K, Jackson P J, Ticknor L O, Keim P and Andersen G L 2003 Genome Differences That Distinguish *Bacillus anthracis* from *Bacillus cereus* and *Bacillus thuringiensis* *Appl. Environ. Microbiol.* **69** 2755-2764
- [15] Turnbull P C B, Hutson R A, Ward M J, Jones M N, Quinn C P, Finnie N J, Duggleby C J, Kramer J M and Melling J 1992 *Bacillus anthracis* but not always anthrax *J. Appl. Bacteriol.* **72** 21-28
- [16] Jackson P J, Hill K K, Pardington P E and Ticknor L O 2001 The relationship of *B. anthracis* to other subgroup 1 *Bacillus* species, In: Program and abstracts book of 4th International conference of Anthrax, Annapolis, Maryland, USA, June 10-13: 15
- [17] Setlow P J 1995 Mechanisms for the prevention of damage to DNA in spores of *Bacillus* species *Annu. Rev. Microbiol.* **49** 29-54
- [18] Setlow P J 1994 Mechanisms which contribute to the long-term survival of spores of *Bacillus* species *Appl. Bacteriol.* **176** (Symp. Suppl.) 49S-60S
- [19] Dietz P, Bohm R and Strauch D 1980 Investigation on disinfection and sterilization of surfaces by ultraviolet radiation *Zbl. Bakt. Hyg.* **171**:158-167
- [20] Wilson J and Russel K 1964 Isolation of *Bacillus anthracis* from soil stored 60 years *J. Bacteriol.* **87** 237
- [21] Coroller L, Leguerinel I and Mafart P 2000 Effect of Water Activities of Heating and Recovery Media on Apparent Heat Resistance of *Bacillus cereus* Spores *Appl. Environ. Microbiol.* **67** 317-22
- [22] Murray T J 1931 Thermal death point II. spores of *Bacillus anthracis* *J. Infect. Dis.* **48**, 457-67
- [23] Stein C D and Rogers H 1945 Observations on the resistance of anthrax spores to heat *Vet. Med.* **50** 406-10
- [24] Rice E W, Rose L J, Johnson C H, Boczek L A, Arduino M J and Reasoner D J 2004 *Emerg. Infect. Dis.* [serial on the Internet, Oct. 2004] <http://www.cdc.gov/ncidod/EID/vol10no10/04-0158.htm>
- [25] Assessment of inadequately filtered public drinking water - Washington, D.C. 1994 *MMWR Morb. Mortal. Wkly. Rep.* **43** 661-9

- [26] Geldreich E E 1989 Drinking water microbiology—new directions toward water quality enhancement *Int. J. Food. Microbiol.* **9** 295–312
- [27] Fayer R 1994 Effect of high temperature on infectivity of *Cryptosporidium parvum* oocysts in water *Appl. Environ. Microbiol.* **60** 2732–2735
- [28] Rosocha L A, Park J, FitzPatrick J R and Herrmann H W 2003 Radiological, Chemical, and Biological Decontamination Using Atmospheric-Pressure Plasmas *Los Alamos National Laboratory Report LALP-03-173*
- [29] Herrmann H W, Henins I, Park J and Selwyn G S 1999 Decontamination of chemical and biological warfare (CBW) agents using an atmospheric pressure plasma jet (APPJ) *Phys. Plasma* **6** 2284-2289
- [30] Lai W, Lai H, Kuo S P, Tarasenko O and Levon K 2005 Decontamination of biological warfare agents by a microwave plasma torch *Phys. Plasmas* **12** 023501-6
- [31] Kuo S P, Bivolaru D, Lai H, Lai W, Popovic S and Kessaratikoon P 2004 Characteristics of an arc-seeded microwave plasma torch *IEEE Trans. Plasma Sci.* **32** 1734-1741
- [32] Bergeret G and Gallezot P 1997 In Handbook of heterogeneous catalysis **2** Ertl, Knözinger G and Weitkamp Jr. H. Eds, Wiley-VCH, Weinheim, Germany
- [33] Georg A, Engemann J and Brockhaus A 2002 Investigation of a pulsed oxygen microwave plasma by time-resolved two-photon allowed laser-induced fluorescence *J. Phys. D: Appl. Phys.* **35** 875-881
- [34] Levine R 2002 Carbonyl modified proteins in cellular regulation, aging, and disease *Free Radical Biology & Medicine* **32** 790-792
- [35] Levine R. and Stadtman E 2001 Oxidative modification of proteins during aging *Experimental Gerontology* **36**1495-1502
- [36] Squier T 2001 Oxidative stress and protein aggregation during biological aging *Exp. Gerontology* **36** 1539-1550